

Name _____ Date ___/___/___

Track location _____
 Track name _____
 Track length _____ m
 Race Event _____
 Practice _____ Qualifying _____ Final _____
 Race duration _____ min.
 Track layout technical _____ fast _____ mixed _____
 Traction low _____ medium _____ high _____
 Temperature Air _____ Track _____
 Results Laps _____ Time _____ Position _____
 Fastest lap _____ Tank duration _____

Engine _____
 Brand _____ Type _____
 Glowplug _____ Shims _____
 Carburator _____ Venturi _____
 Exhaust _____
 Manifold _____
 Muffler _____
 Fuel Brand _____ Nitro _____ %

Clutch Type _____
 Clutch shoe _____ Flyweights _____ Spring _____
 Bell clearance _____ Preload _____

Drive ratio
 1st gear clutch bell 17 18 2nd gear clutch bell 21 22 23
 1st gear gearbox 58 59 60 2nd gear gearbox 53 54 55

Tyres
 Front left/right _____ Brand _____
 _____ Shore _____
 _____ Diameter start _____
 _____ Diameter end _____
 Rear left/right _____

Front differential _____
 Differential _____ Solid axle _____ One way _____
 Oil _____ cST
 Rear differential _____
 Oil _____ cST

Body Brand _____ Type _____
 Distance from bumper _____ mm
 Spoiler width _____ mm height _____ mm
 Position distance to body rear _____ mm
 Winglets _____ mm x _____ mm

Notes _____

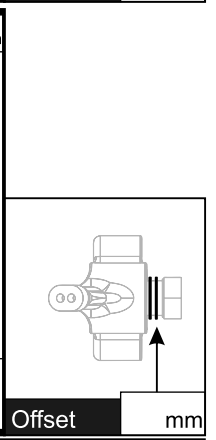
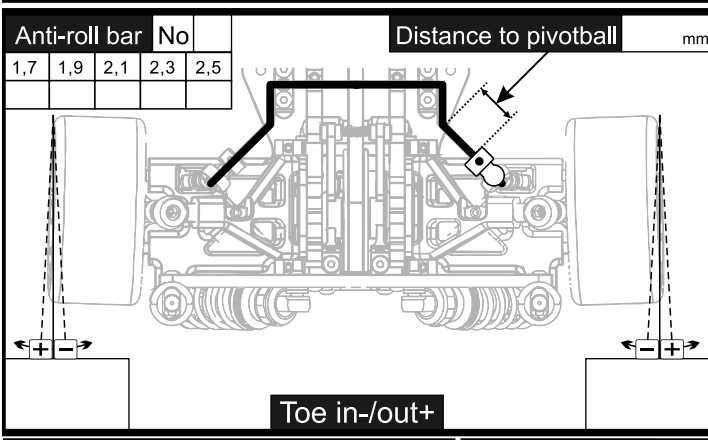
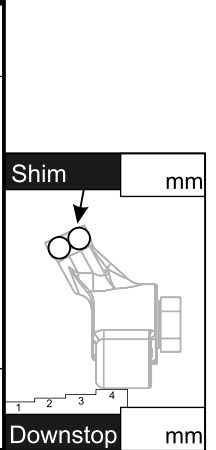
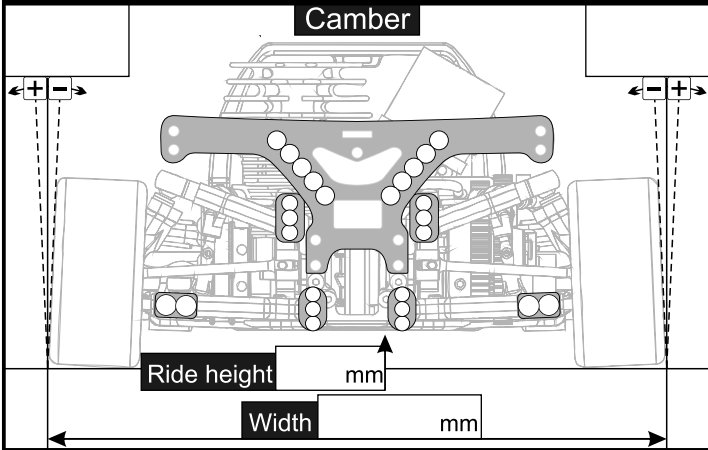
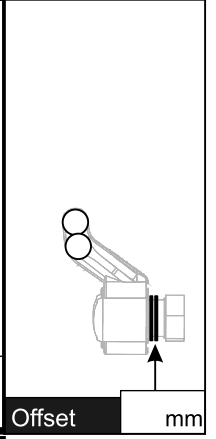
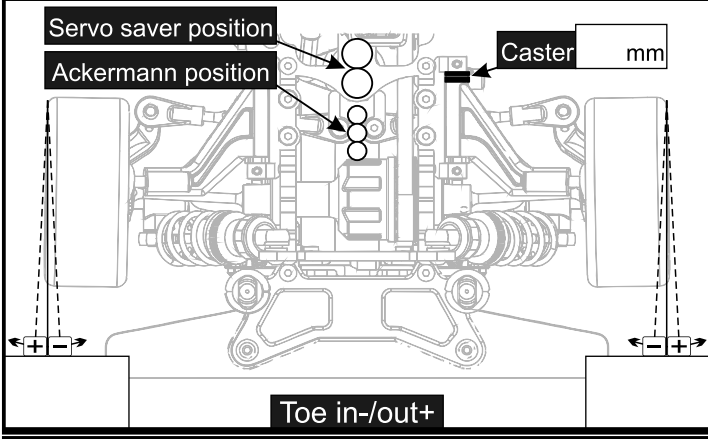
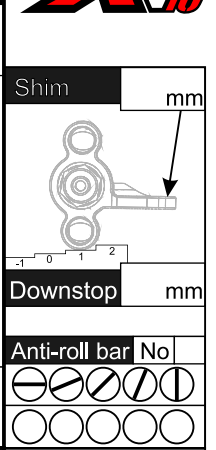
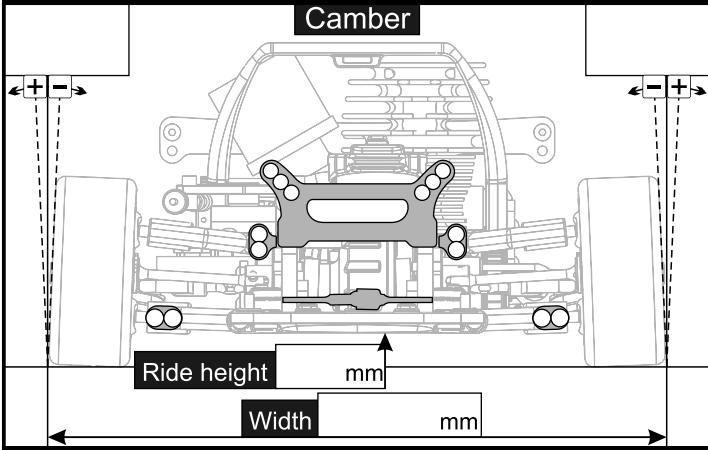

Rear Shocks
 Piston 1hole _____ 2hole _____ 3hole _____
 Spring floating piston Soft _____ Hard _____
 Shock oil _____
 Spring _____

Front Shocks
 Piston 1hole _____ 2hole _____ 3hole _____
 Spring floating piston Soft _____ Hard _____
 Shock oil _____
 Spring _____