

Name Rony Yokoyama

Date 12 / 13 / 2009

Track location			
Track name	標準セット		
Track length	m		
Race Event			
Practice	Qualifying	Final	
Race duration	min.		
Track layout	technical	fast	mixed
Traction	low	medium	high
Temperature	Air	Track	
Results	Laps	Time	Position
	Fastest lap	Tank duration	

Engine			
Brand	Type		
Glowplug	Shims		
Carburator	Venturi		
Exhaust			
Manifold			
Muffler			
Fuel	Brand	Rony	Nitro 16 %

Clutch	Type	VCC V10	
Clutch shoe	Flyweights	Spring	
std	std	std	
Bell clearance	Preload		
0.45	0.35		

Drive ratio			
1st gear clutch bell	2nd gear clutch bell		
17 ● 18	21 ● 22	23	
1st gear gearbox	2nd gear gearbox		
58 59 ● 60	53 54 ● 55		

Tyres			
Front left/right	Brand	Rear left/right	
Active /Active	Shore	37 / 37	
SPor33 /SPor33	Diameter start	62 / 62	
59 / 59	Diameter end	58 / 58	
56 / 56			

Front differential			
Differential	● Solid axle	One way	
Oil	300000	cST	
Rear differential			
Oil	80000	cST	

Body	Brand	Shepherd	Type	Aydi A5
Distance from bumper	mm			
Spoiler	width	mm	height	mm
Position	distance to body rear mm			
Winglets	mm x		mm	

Notes タイヤ径については、各サーキットにて変えて下さい。

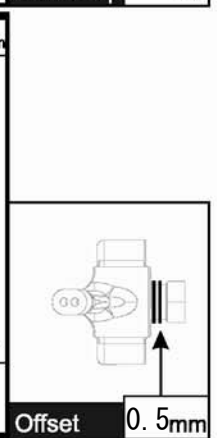
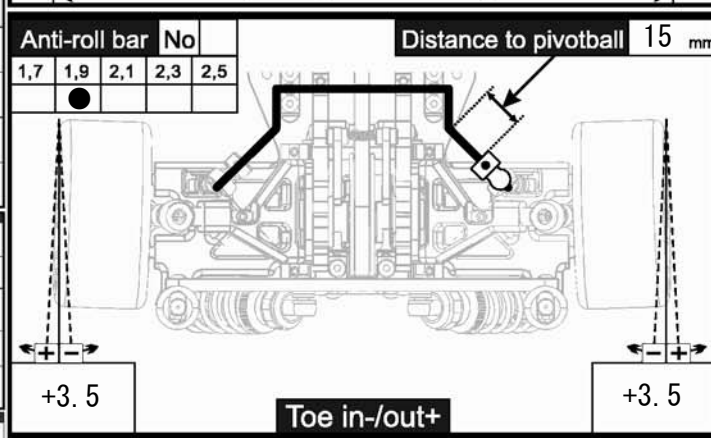
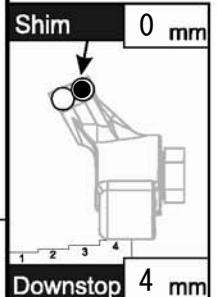
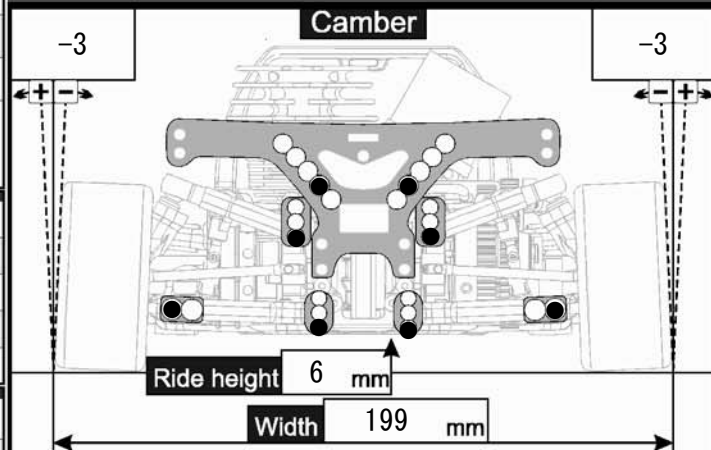
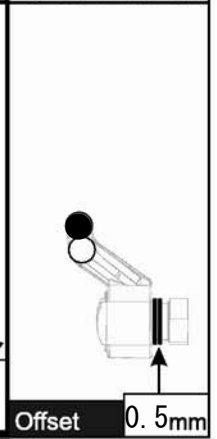
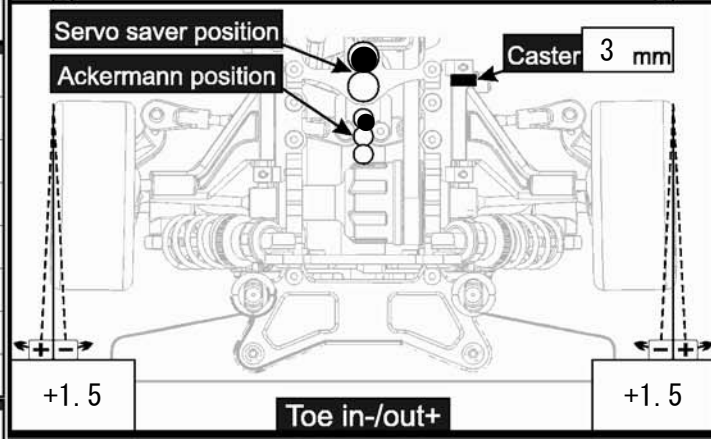
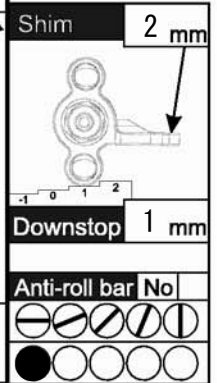
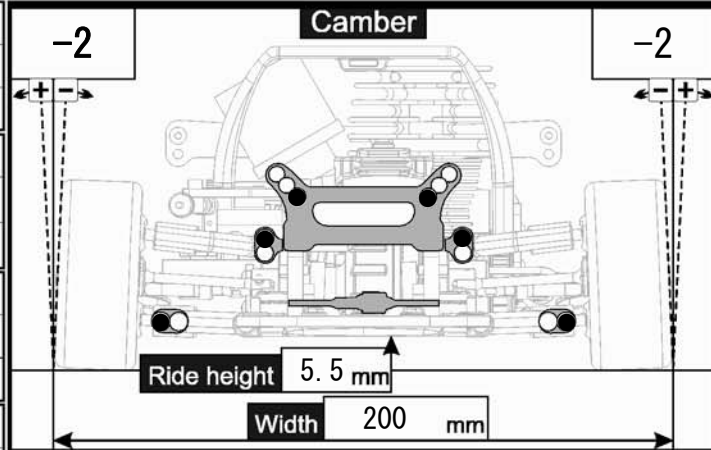

Rear Shocks				
Piston	1hole	2hole	1.1	3hole
Spring floating piston	Soft	Hard		
Shock oil	400			
Spring	Serpent OLD Yellow			

Front Shocks				
Piston	1hole	2hole	1.1	3hole
Spring floating piston	Soft	Hard		
Shock oil	400			
Spring	Serpent OLD Yellow			