

VELOX SET-UP SHEET

Name: _____
 Date: _____
 Track: _____

Track condition:
 Surface: SMOOTH MEDIUM BUMPY
 Size: TIGHT MEDIUM FAST
 Traction: LOW MEDIUM HIGH

Engine

Engine	Muffler	Manifold	Plug

Clutch

Clutch shoe	Centrifugal shoe	Spring

Clutch bell clearance/mm	Adj. nut position/mm

Drive ratio

Pinion 1st	Pinion 2nd	Pulley
<input type="radio"/> 16	<input type="radio"/> 19	<input type="radio"/> 26
<input type="radio"/> 17	<input type="radio"/> 20	<input type="radio"/> 25
	<input type="radio"/> 21	

Spur 1st	Spur 2nd
<input type="radio"/> 48	<input type="radio"/> 45
<input type="radio"/> 49	<input type="radio"/> 46
<input type="radio"/> 50	<input type="radio"/> 47

Tyres

Front left/right	brand	Rear left/right
/		/
/	shore	/
/	diameter start/mm	/
/	diameter end/mm	/

Body

Body position/mm	Spoiler position/mm

Rear shock

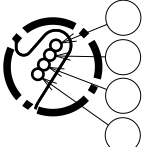
	Piston (hole)	
	Oil	
	Spring	

Front shock

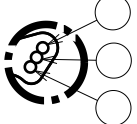
	Piston (hole)	
	Oil	
	Spring	

Steering Ackermann

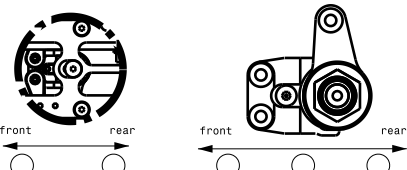
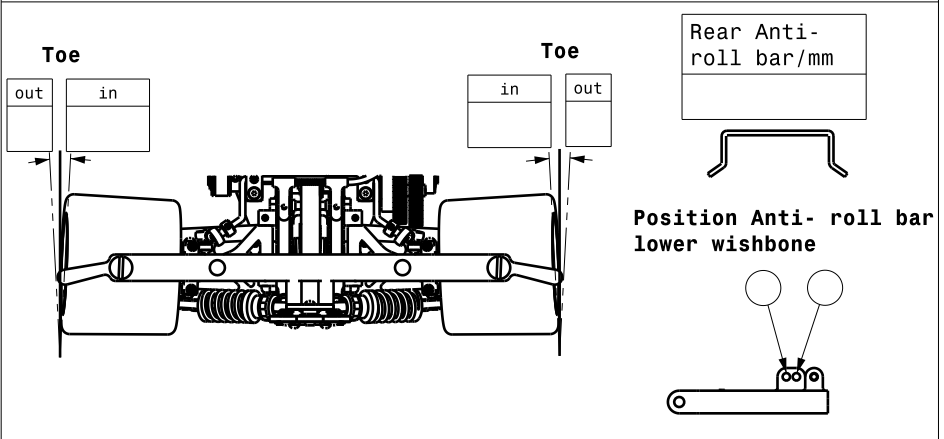
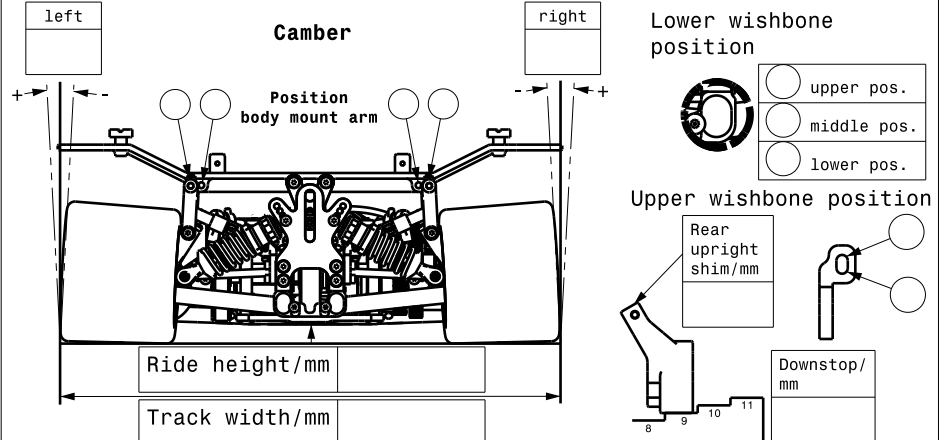
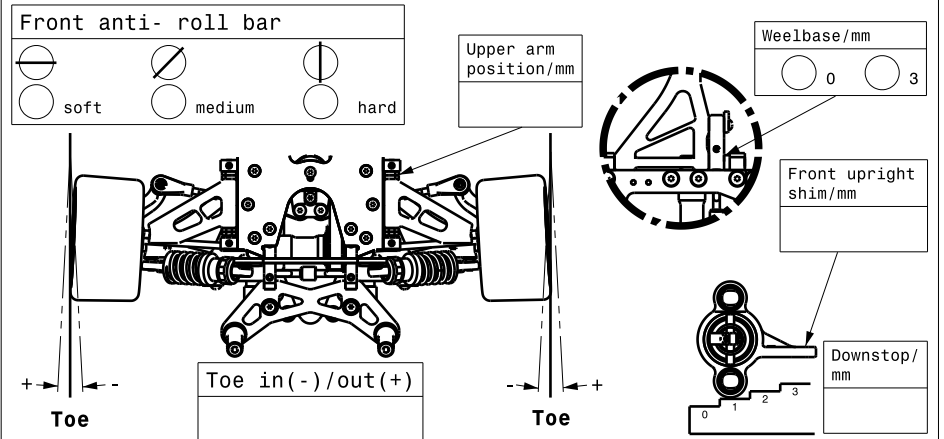
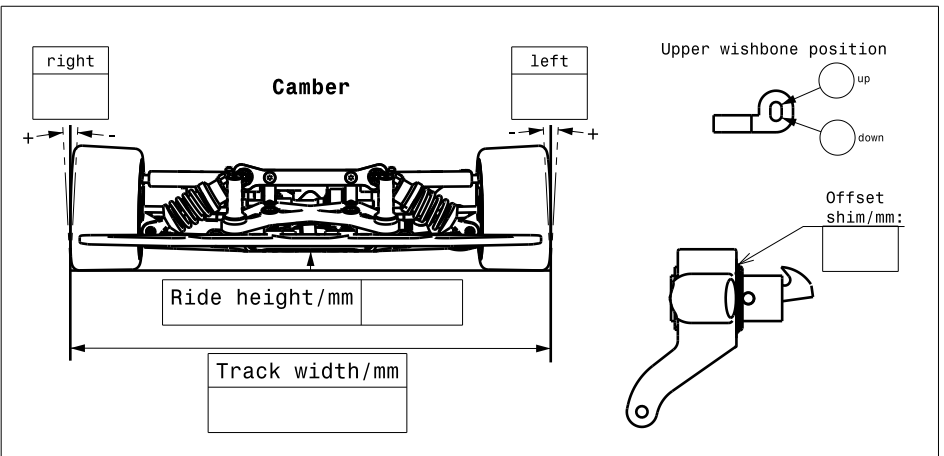
Comments: