

Name:
Date:
Track:

VELOX SET-UP SHEET

SHEPHERD MICRO RACING

Track condition:
Surface: SMOOTH MEDIUM BUMPY
Size: TIGHT MEDIUM FAST
Traction: LOW MEDIUM HIGH

Engine

Engine	Muffler	Manifold	Plug
Novarossi	2015	Short	7tf

Clutch

Clutch shoe	Centrifugal shoe	Spring
Black	Original	Original

Clutch bell clearance/mm	Adj. nut position/mm
0,6	1,2

Drive ratio

Pinion 1st	Pinion 2nd	Pulley
<input type="radio"/> 16 <input checked="" type="radio"/> 17	<input type="radio"/> 19 <input checked="" type="radio"/> 20 <input type="radio"/> 21	<input checked="" type="radio"/> 26 <input type="radio"/> 25

Spur 1st	Spur 2nd
<input type="radio"/> 48 <input checked="" type="radio"/> 49 <input type="radio"/> 50	<input type="radio"/> 45 <input checked="" type="radio"/> 46 <input type="radio"/> 47

Tyres

Front left/right	brand	Rear left/right
PMT / PMT		PMT / PMT
32 / 32	shore	35 / 35
67 / 67	diameter start/mm	74 / 74
/	diameter end/mm	/

Body

Body position/mm	Spoiler position/mm
15	10

Rear shock

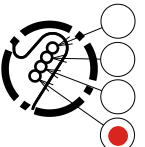
	Position	
	Piston (hole)	2
	Oil	650
	Spring	Blau

Front shock

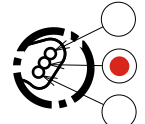
	Position	
	Piston (hole)	1
	Oil	650
	Spring	Blau

Steering Ackermann

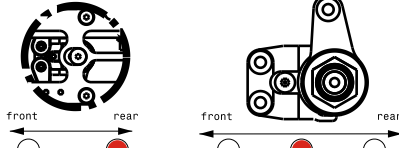
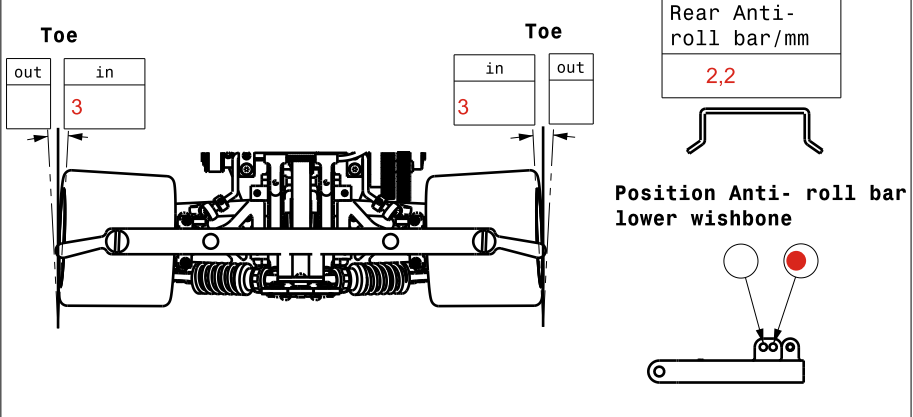
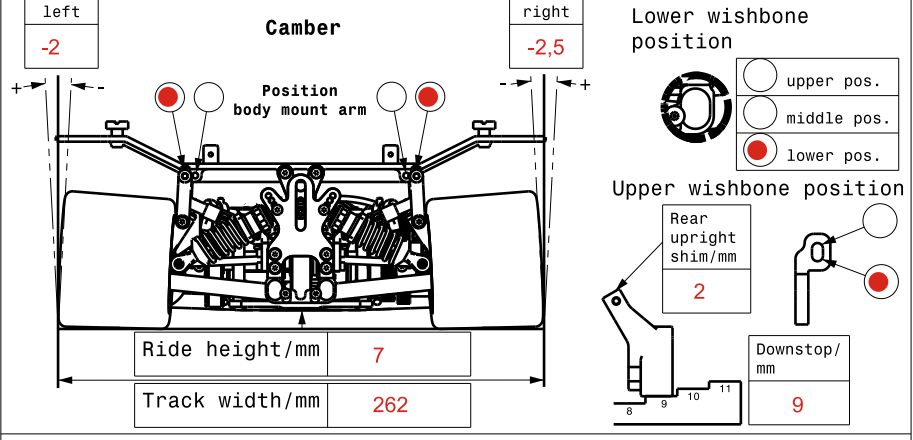
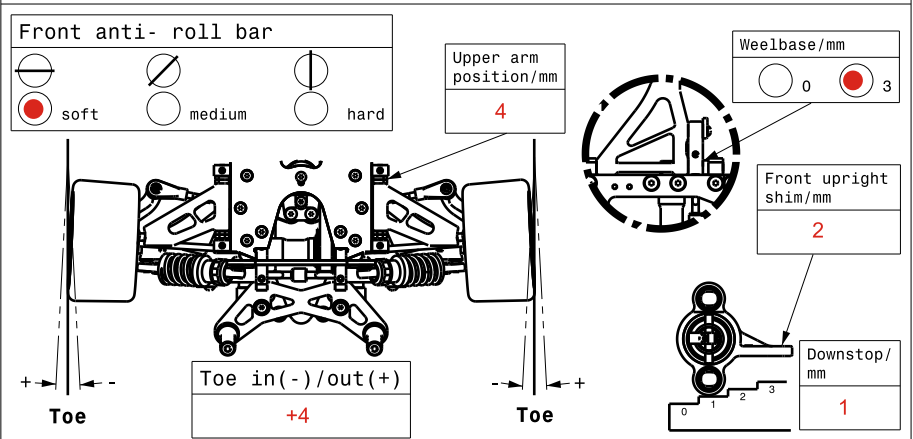
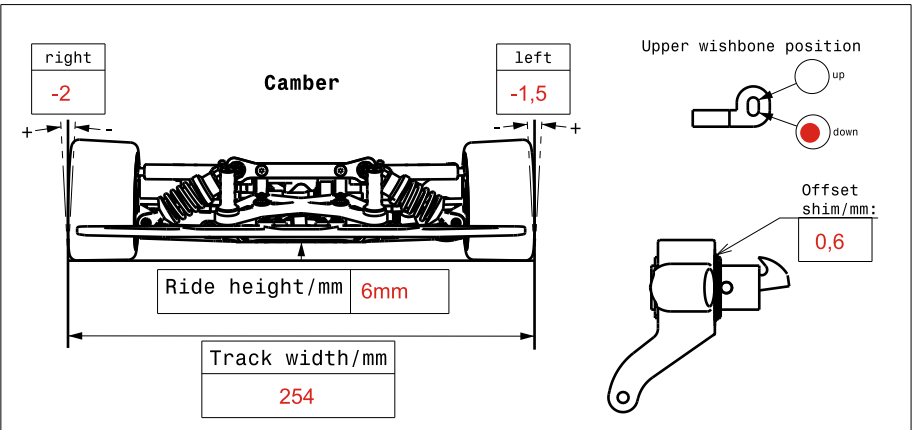
Comments: